

AVTECH ELECTROSYSTEMS LTD.

NANOSECOND WAVEFORM ELECTRONICS
SINCE 1975

P.O. BOX 265
OGDENSBURG, NY
U.S.A. 13669-0265
TEL: (315) 472-5270
FAX: (613) 226-2802

TEL: 1-800-265-6681
FAX: 1-800-561-1970

e-mail: info@avtechpulse.com
<http://www.avtechpulse.com/>

BOX 5120, LCD MERIVALE
OTTAWA, ONTARIO
CANADA K2C 3H4
TEL: (613) 226-5772
FAX: (613) 226-2802

INSTRUCTIONS

MODEL AV-1021D-B

DUAL-CHANNEL, 0 TO ± 10 VOLTS, 10 MHz
GENERAL PURPOSE LAB PULSE GENERATOR
WITH IEEE 488.2 AND RS-232 CONTROL

SERIAL NUMBER: _____

WARRANTY

Avtech Electrosystems Ltd. warrants products of its manufacture to be free from defects in material and workmanship under conditions of normal use. If, within one year after delivery to the original owner, and after prepaid return by the original owner, this Avtech product is found to be defective, Avtech shall at its option repair or replace said defective item. This warranty does not apply to units which have been disassembled, modified or subjected to conditions exceeding the applicable specifications or ratings. This warranty is the extent of the obligation assumed by Avtech with respect to this product and no other warranty or guarantee is either expressed or implied.

TECHNICAL SUPPORT

Phone: 613-226-5772 or 1-800-265-6681

Fax: 613-226-2802 or 1-800-561-1970

E-mail: info@avtechpulse.com

World Wide Web: <http://www.avtechpulse.com>

TABLE OF CONTENTS

WARRANTY	2
TECHNICAL SUPPORT	2
TABLE OF CONTENTS	3
INTRODUCTION	5
SPECIFICATIONS	6
EC DECLARATION OF CONFORMITY	7
INSTALLATION	8
VISUAL CHECK	8
POWER RATINGS	8
CONNECTION TO THE POWER SUPPLY	8
ENVIRONMENTAL CONDITIONS	8
FUSES	9
AC FUSE REPLACEMENT	9
DC FUSE REPLACEMENT	10
FUSE RATINGS	10
FRONT PANEL CONTROLS	11
REAR PANEL CONTROLS	13
GENERAL INFORMATION	15
BASIC PULSE CONTROL	15
TRIGGER MODES	18
GATING	18
SPECIAL CHANNEL 1 MODES: DC Output	18
SPECIAL CHANNEL 1 MODES: Double Pulse	18
SPECIAL CHANNEL 1 MODES: PWIN=PWOUT Mode	18
OUTPUT TERMINATION	19
OPERATIONAL CHECK	20
MECHANICAL INFORMATION	24
TOP COVER REMOVAL	24
RACK MOUNTING	24
ELECTROMAGNETIC INTERFERENCE	24
MAINTENANCE	25
REGULAR MAINTENANCE	25

CLEANING.....	25
PROGRAMMING YOUR PULSE GENERATOR.....	26
KEY PROGRAMMING COMMANDS.....	26
ALL PROGRAMMING COMMANDS.....	27
WIRING DIAGRAMS.....	29
WIRING OF AC POWER.....	29
PCB 158D - LOW VOLTAGE POWER SUPPLY, 1/3.....	30
PCB 158D - LOW VOLTAGE POWER SUPPLY, 2/3.....	31
PCB 158D - LOW VOLTAGE POWER SUPPLY, 3/3.....	32
MAIN SIGNAL WIRING.....	33
PCB 100 - PULSER SCHEMATIC, 1/4.....	34
PCB 100 - PULSER SCHEMATIC, 2/4.....	35
PCB 100 - PULSER SCHEMATIC, 3/4.....	36
PCB 100 - PULSER SCHEMATIC, 4/4.....	37
PERFORMANCE CHECK SHEET.....	38

Manual Reference: T:\instructword\av-1020\av-1021d-b,edition3.sxw.
 Last modified September 28, 2004.
 Copyright © 2004 Avtech Electrosystems Ltd, All Rights Reserved.

INTRODUCTION

The AV-1021D-B is a dual-channel, general-purpose, GPIB and RS232-equipped instrument capable of generating $\pm 10\text{V}$ into 50Ω loads at repetition rates up to 10 MHz. Pulse width and delay are variable up to 500 ms. Rise and fall times are fixed at less than 10 ns.

The AV-1021D-B is a highly flexible instrument. Aside from the internal trigger source, it can also be triggered or gated by external TTL-level signals. A front-panel pushbutton or a computer command can also be used to trigger the instrument. Both output channels are triggered by a common source. The relative delay between the two channels can be adjusted from 0 to 500 ms. The two output channels offer independent control of amplitude, offset, pulse width, and output impedance.

The source resistance of both output channels can be set at either 2 or 50Ω . In the 2Ω setting, the maximum voltage available from the main output is $\pm 10\text{V}$. The pulse amplitude can be varied between 0 and $\pm 10\text{V}$, as can the DC offset voltage. In the 50Ω setting the maximum voltage available (into a 50Ω load) is $\pm 5\text{V}$. The 50Ω setting is useful for transmission line backmatching.

Besides the two main outputs, there are four auxiliary outputs on the rear-panel. For each of the two output channels, LOGIC and inverse-LOGIC connectors are supplied, which can be set to generate TTL- or ECL-level pulses.

The AV-1021D-B features front panel keyboard and adjust knob control of the output pulse parameters along with a four line by 40 character back-lit LCD display of the output amplitude, polarity, pulse width, pulse repetition frequency, source resistance and delay. The instrument includes memory to store up to four complete instrument setups. The operator may use the front panel or the computer interface to store a complete "snapshot" of all key instrument settings, and recall this setup at a later time.

This instrument is intended for use in research and development laboratories.

SPECIFICATIONS

Model:	AV-1021D-B
GPIB and RS-232 control:	Included. See http://www.avtechpulse.com/gpib for details.
LabView Drivers:	Check http://www.avtechpulse.com/labview/ for availability and downloads
Number of main output channels:	Two
Auxiliary logic-level outputs:	Logic and Logic-Inverted, for both channels. May be set to TTL or ECL levels.
Amplitude and peak output (to 50 Ohms) ¹ :	Main output: 0 to ± 10 V (when $Z_{OUT}=2\Omega$), 0 to ± 5 V (when $Z_{OUT}=50\Omega$). Resolution: < 0.025% of full-scale. Logic outputs: TTL: 0 and +5V. ECL: -0.8V and -1.6V.
Pulse repetition frequency (PRF):	1 Hz to 10 MHz
Pulse width (FWHM):	30 ns to 0.5 sec
Rise time, fall time (20%-80%):	Main: ≤ 10 ns (≤ 5 ns optional ²), TTL: 5 ns, ECL: 2 ns
DC offset ¹ :	0 to ± 10 V for $Z_{OUT}=2\Omega$, 0 to ± 5 V for $Z_{OUT}=50\Omega$
Source impedance Z_{OUT} :	Main output: 2Ω or 50Ω , switchable ² .
Polarity (main output):	Positive or negative
Duty cycle (max):	80% (100% in PW DC mode)
Waveform aberrations:	Overshoot and ringing are less than $\leq 10\%$ at amplitudes of 1 V and higher with outputs terminating in 50Ω .
Propagation delay:	< 120 ns (Ext trig in to pulse out, with delay set to zero)
Trigger required (Ext trig mode):	+ 5 Volts, ≥ 4 ns TTL
Trigger required (Gate in):	TTL, synchronous, active high or low
Delay jitter:	$\leq \pm 35$ ps $\pm 0.015\%$ RMS (sync out to pulse out)
Delay:	Channel 1: follows sync pulse by 0 to 0.5 sec Channel 2: synchronous with sync pulse
Sync output:	+2 Volts, 50 ns, will drive 50 Ohm loads
Single pulse mode:	manual front-panel push button or computer command
Double pulse mode:	Channel 1 only
Signal connectors:	BNC
Power requirement:	100 - 240 Volts, 50 - 60 Hz
Dimensions, Weight, Chassis:	100 x 430 x 375 mm (3.9" x 17" x 14.8"), 10 kg (22 lbs), anodized aluminum with blue-gray plastic trim
Mounting & Temperature range:	Any, +5°C to +40°C

- 1) Peak output = amplitude + offset. The amplitude and offset can not be set to maximum at the same time, or the peak output rating will be exceeded.
- 2) Add the suffix -TR to the model number to specify the 5 ns rise time option. The minimum Z_{OUT} increases from 2Ω to 6Ω when -TR option is present.

EC DECLARATION OF CONFORMITY

We

Avtech Electrosystems Ltd.
P.O. Box 5120, LCD Merivale
Ottawa, Ontario
Canada K2C 3H4

declare that this pulse generator meets the intent of Directive 89/336/EEC for Electromagnetic Compatibility. Compliance pertains to the following specifications as listed in the official Journal of the European Communities:

EN 50081-1 Emission

EN 50082-1 Immunity

and that this pulse generator meets the intent of the Low Voltage Directive 72/23/EEC as amended by 93/68/EEC. Compliance pertains to the following specifications as listed in the official Journal of the European Communities:

EN 61010-1:2001 Safety requirements for electrical equipment for measurement, control, and laboratory use



INSTALLATION

VISUAL CHECK

After unpacking the instrument, examine to ensure that it has not been damaged in shipment. Visually inspect all connectors, knobs, liquid crystal displays (LCDs), and the handles. Confirm that a power cord, a GPIB cable, and two instrumentation manuals (this manual and the “Programming Manual for -B Instruments”) are with the instrument. If the instrument has been damaged, file a claim immediately with the company that transported the instrument.

POWER RATINGS

This instrument is intended to operate from 100 - 240 V, 50 - 60 Hz.

The maximum power consumption is 90 Watts. Please see the “FUSES” section for information about the appropriate AC and DC fuses.

This instrument is an “Installation Category II” instrument, intended for operation from a normal single-phase supply.

CONNECTION TO THE POWER SUPPLY

An IEC-320 three-pronged recessed male socket is provided on the back panel for AC power connection to the instrument. One end of the detachable power cord that is supplied with the instrument plugs into this socket. The other end of the detachable power cord plugs into the local mains supply. Use only the cable supplied with the instrument. The mains supply must be earthed, and the cable used to connect the instrument to the mains supply must provide an earth connection. (The supplied cable does this.)

ENVIRONMENTAL CONDITIONS

This instrument is intended for use under the following conditions:

1. indoor use;
2. altitude up to 2 000 m;
3. temperature 5 °C to 40 °C;
4. maximum relative humidity 80 % for temperatures up to 31 °C decreasing linearly to 50 % relative humidity at 40 °C;
5. Mains supply voltage fluctuations up to ± 10 % of the nominal voltage;
6. no pollution or only dry, non-conductive pollution.

FUSES

This instrument contains four fuses. All are accessible from the rear-panel. Two protect the AC prime power input, and two protect the internal DC power supplies. The locations of the fuses on the rear panel are shown in the figure below:

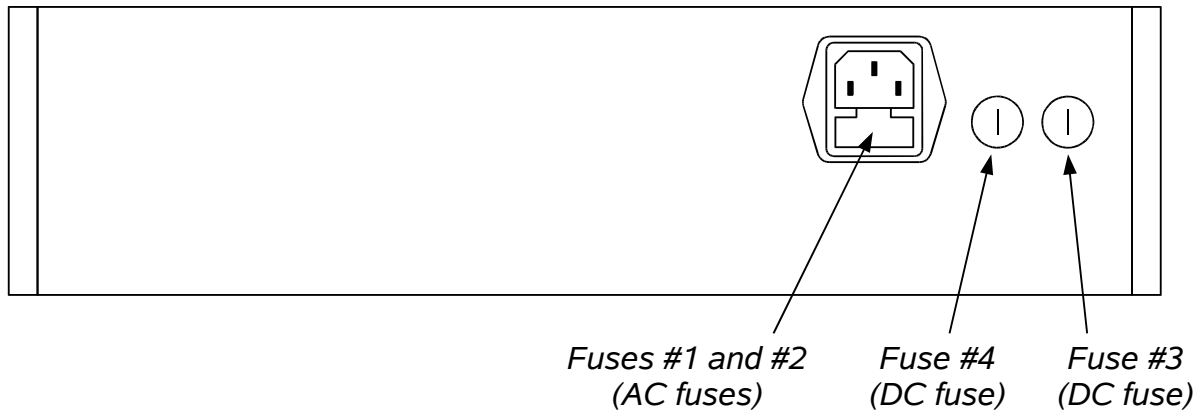

AC FUSE REPLACEMENT

To physically access the AC fuses, the power cord must be detached from the rear panel of the instrument. The fuse drawer may then be extracted using a small flat-head screwdriver, as shown below:

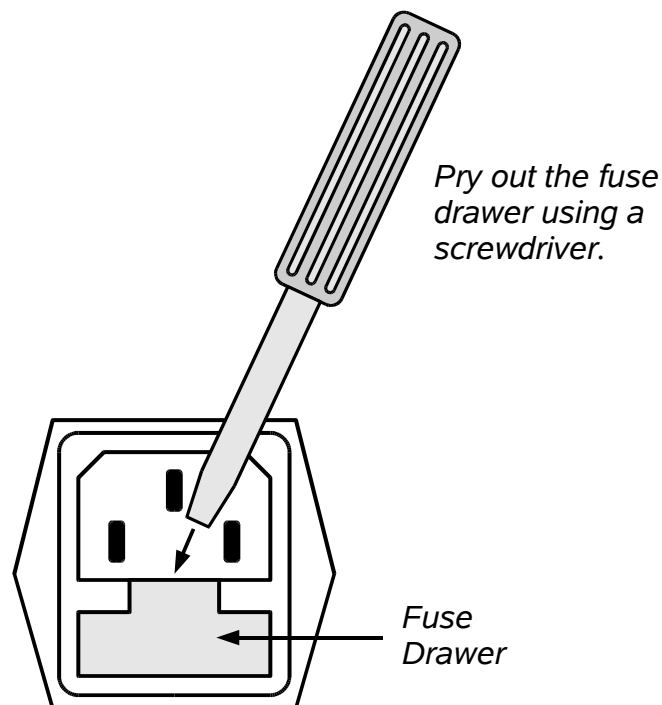

DC FUSE REPLACEMENT

The DC fuses may be replaced by inserting the tip of a flat-head screwdriver into the fuse holder slot, and rotating the slot counter-clockwise. The fuse and its carrier will then pop out.

FUSE RATINGS

The following table lists the required fuses:

Fuses	Nominal Mains Voltage	Rating	Case Size	Manufacturer's Part Number (Wickmann)	Distributor's Part Number (Digi-Key)
#1, #2 (AC)	115 V	0.8A, 250V, Time-Delay	5×20 mm	1950800000	WK5046-ND
	230 V	0.5A, 250V, Time-Delay	5×20 mm	1950500000	WK5041-ND
#3 (DC)	N/A	1.6A, 250V, Time-Delay	5×20 mm	1951160000	WK5053-ND
#4 (DC)	N/A	Not used. A spare 1.6A fuse is installed here.			

The fuse manufacturer is Wickmann (<http://www.wickmann.com/>).

Replacement fuses may be easily obtained from Digi-Key (<http://www.digikey.com/>) and other distributors.

FRONT PANEL CONTROLS

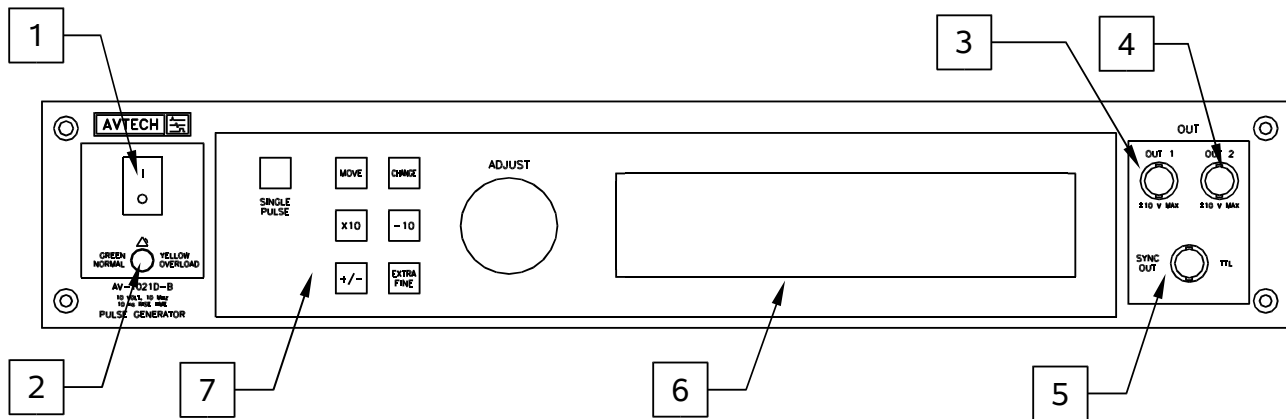

1. POWER Switch. This is the main power switch. When turning the instrument on, there may be a delay of several seconds before the instrument appears to respond.
2. OVERLOAD Indicator. When the instrument is powered, this indicator is normally green, indicating normal operation. If this indicator is yellow, an internal automatic overload protection circuit has been tripped. If the unit is overloaded (by operating at an exceedingly high duty cycle or by operating into a very low impedance), the protective circuit will disable the output of the instrument and turn the indicator light yellow. The light will stay yellow (i.e. output disabled) for about 5 seconds after which the instrument will attempt to re-enable the output (i.e. light green) for about 1 second. If the overload condition persists, the output will be disabled again (i.e. light yellow) for another 5 seconds. If the overload condition has been removed, the instrument will resume normal operation.

This overload indicator may flash yellow briefly at start-up. This is not a cause for concern.
3. OUT 1 CONNECTOR. This BNC connector provides the main output signal for Channel 1, into load impedances of 50Ω or higher. It can generate voltages of up to $\pm 10V$.
4. OUT 2 CONNECTOR. This BNC connector provides the main output signal for Channel 2, into load impedances of 50Ω or higher. It can generate voltages of up to $\pm 10V$.
5. SYNC OUT. This connector supplies a SYNC output that can be used to trigger other equipment, particularly oscilloscopes. This signal leads (or lags) the main output by a duration set by the "DELAY" controls and has an approximate amplitude of +3 Volts to $R_L > 50\Omega$ with a pulse width of approximately 50 ns.
6. LIQUID CRYSTAL DISPLAY (LCD). This LCD is used in conjunction with the keypad to change the instrument settings. Normally, the main menu is displayed, which lists the key adjustable parameters and their current values. The

“Programming Manual for -B Instruments” describes the menus and submenus in detail.

7. KEYPAD.

Control Name	Function
MOVE	This moves the arrow pointer on the display.
CHANGE	This is used to enter the submenu, or to select the operating mode, pointed to by the arrow pointer.
×10	If one of the adjustable numeric parameters is displayed, this increases the setting by a factor of ten.
÷10	If one of the adjustable numeric parameters is displayed, this decreases the setting by a factor of ten.
+/-	If one of the adjustable numeric parameters is displayed, and this parameter can be both positive or negative, this changes the sign of the parameter.
EXTRA FINE	This changes the step size of the ADJUST knob. In the extra-fine mode, the step size is twenty times finer than in the normal mode. This button switches between the two step sizes.
ADJUST	This large knob adjusts the value of any displayed numeric adjustable values, such as frequency, pulse width, etc. The adjust step size is set by the "EXTRA FINE" button. When the main menu is displayed, this knob can be used to move the arrow pointer.

REAR PANEL CONTROLS

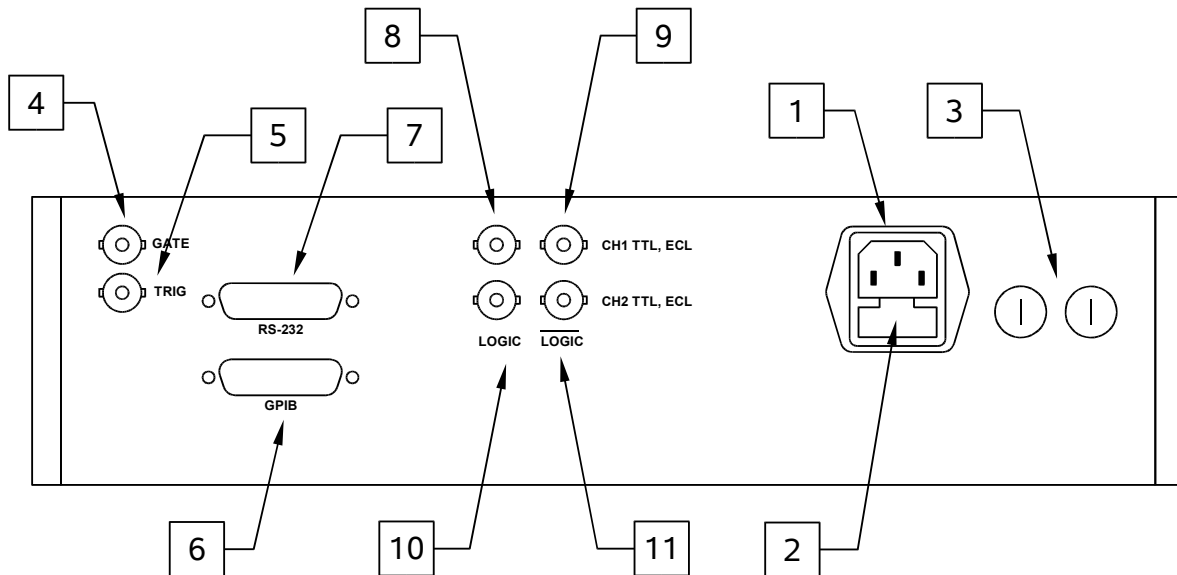

1. AC POWER INPUT. An IEC-320 C14 three-pronged recessed male socket is provided on the back panel for AC power connection to the instrument. One end of the detachable power cord that is supplied with the instrument plugs into this socket.
2. AC FUSE DRAWER. The two fuses that protect the AC input are located in this drawer. Please see the “FUSES” section of this manual for more information.
3. DC FUSES. These two fuses protect the internal DC power supplies. Please see the “FUSES” sections of this manual for more information.
4. GATE. This TTL-level (0 and +5V) logic input can be used to gate the triggering of the instrument. This input can be either active high or active low, depending on the front panel settings or programming commands. (The instrument triggers normally when this input is unconnected). When set to active high mode, this input is pulled-down to ground by a 1 k Ω resistor. When set to active low mode, this input is pulled-up to +5V by a 1 k Ω resistor.
5. TRIG. This TTL-level (0 and +5V) logic input can be used to trigger the instrument, if the instrument is set to triggering externally. The instrument triggers on the rising edge of this input. The input impedance of this input is 1 k Ω . (Depending on the length of cable attached to this input, and the source driving it, it may be desirable to add a coaxial 50 Ohm terminator to this input to provide a proper transmission line termination. The Pasternack (www.pasternack.com) PE6008-50 BNC feed-thru 50 Ohm terminator is suggested for this purpose.)

When triggering externally, the instrument can be set such that the CH1 output pulse width tracks the pulse width on this input, or the output pulse width can be set

independently.

6. GPIB Connector. A standard GPIB cable can be attached to this connector to allow the instrument to be computer-controlled. See the “Programming Manual for -B Instruments” for more details on GPIB control.
7. RS-232 Connector. A standard serial cable with a 25-pin male connector can be attached to this connector to allow the instrument to be computer-controlled. See the “Programming Manual for -B Instruments” for more details on RS-232 control.
8. CH1 LOGIC Output. The signal on this output has approximately the timing parameters as the Channel 1 main output (i.e. frequency, pulse width, and delay) but the amplitude is fixed at either TTL logic levels (0 and +5V, approximately) or ECL logic levels (-1.6V and -0.8V, approximately), depending on the settings. When using this output, it is recommended that it be terminated with a 50 Ω load.
9. CH1 LOGIC-Complement Output. The signal on this output is the logical complement of the signal on the CH1 LOGIC output (item 8). That is, the high and low logic levels are reversed.
10. CH2 LOGIC Output. The signal on this output has approximately the timing parameters as the Channel 2 main output (i.e. frequency, pulse width, and delay) but the amplitude is fixed at either TTL logic levels (0 and +5V, approximately) or ECL logic levels (-1.6V and -0.8V, approximately), depending on the settings. When using this output, it is recommended that it be terminated with a 50 Ω load.
11. CH2 LOGIC-Complement Output. The signal on this output is the logical complement of the signal on the CH2 LOGIC output (item 10). That is, the high and low logic levels are reversed.

GENERAL INFORMATION

BASIC PULSE CONTROL

This instrument can be triggered by its own internal clock or by an external TTL trigger signal. In either case, a total of seven output channels respond to the trigger: OUT, SYNC, LOGIC, and LOGIC-Complement.

- OUT 1. This is the main output for Channel 1. The pulse width, amplitude, and offset are all adjustable. The maximum output voltage is $\pm 10\text{V}$. (This voltage is reduced by a factor of two if the output impedance is set at 50Ω , and a 50Ω load is used.) This channel can be delayed relative to OUT 2.
- OUT 2. This is the main output for Channel 2. The pulse width, amplitude, and offset are all adjustable. The maximum output voltage is $\pm 10\text{V}$. (This voltage is reduced by a factor of two if the output impedance is set at 50Ω , and a 50Ω load is used.) The delay of this channel is fixed relative to the SYNC output.
- SYNC. The SYNC pulse is a fixed-width TTL-level reference pulse used to trigger oscilloscopes or other measurement systems. It precedes all other outputs.
- CH1 LOGIC. The signal on this output has approximately the timing parameters as OUT 1 (i.e. frequency, pulse width, and delay) but the amplitude is fixed at either TTL logic levels (0 and +5V, approximately) or ECL logic levels (-1.6V and -0.8V, approximately), depending on the settings. This output should be terminated with a 50Ω load.
- CH1 LOGIC-Complement. The signal on this output is the logical complement of the signal on the CH1 LOGIC output. That is, the high and low logic levels are reversed. This output should be terminated with a 50Ω load.
- CH2 LOGIC. The signal on this output has approximately the timing parameters as OUT 1 (i.e. frequency, pulse width, and delay) but the amplitude is fixed at either TTL logic levels (0 and +5V, approximately) or ECL logic levels (-1.6V and -0.8V, approximately), depending on the settings. This output should be terminated with a 50Ω load.
- CH2 LOGIC-Complement. The signal on this output is the logical complement of the signal on the CH2 LOGIC output. That is, the high and low logic levels are reversed. This output should be terminated with a 50Ω load.

These pulses are illustrated below, assuming internal triggering and a non-zero delay setting:

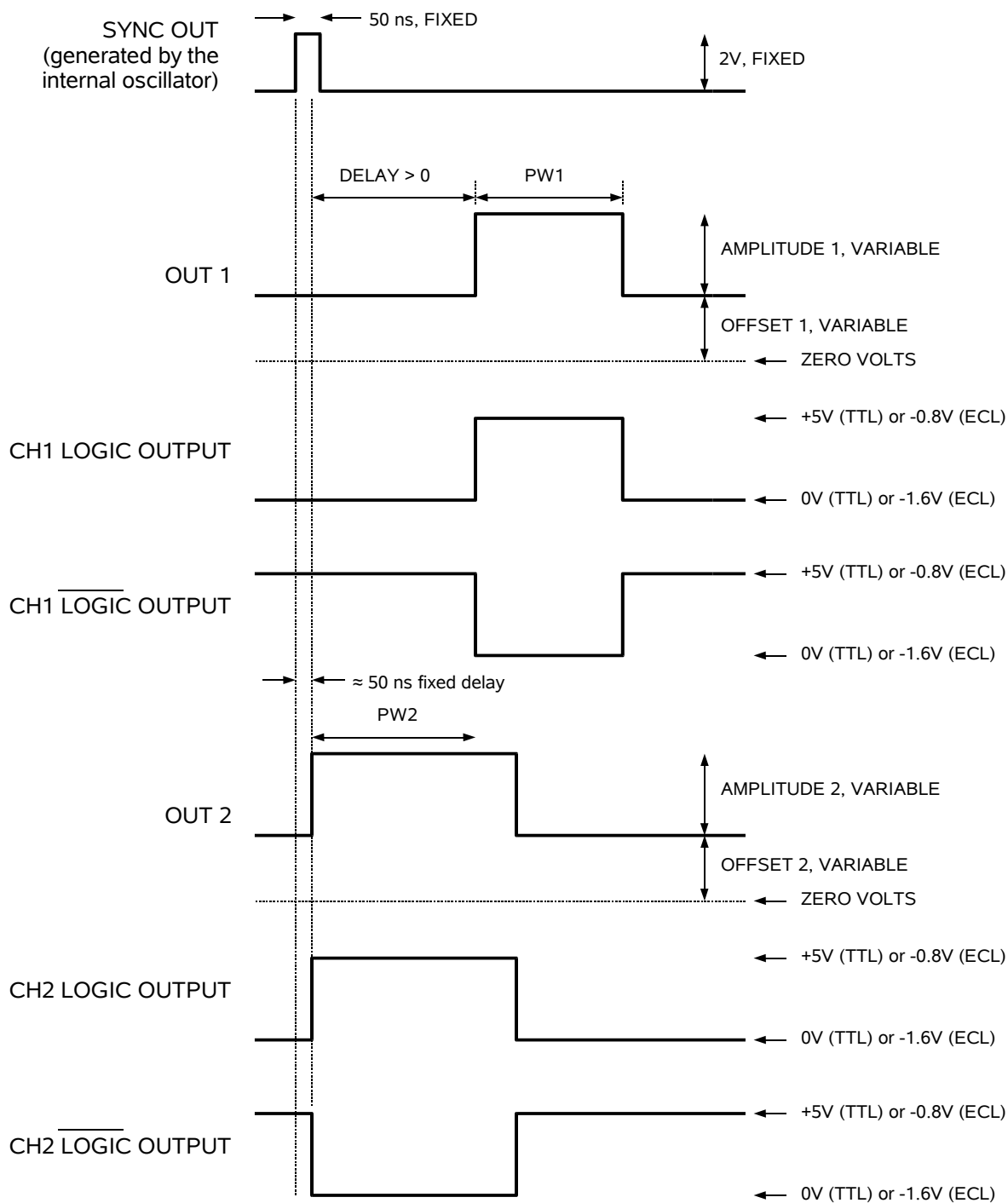

Figure A

The next figure illustrates the relationship between the signal when an external TTL-level trigger is used:

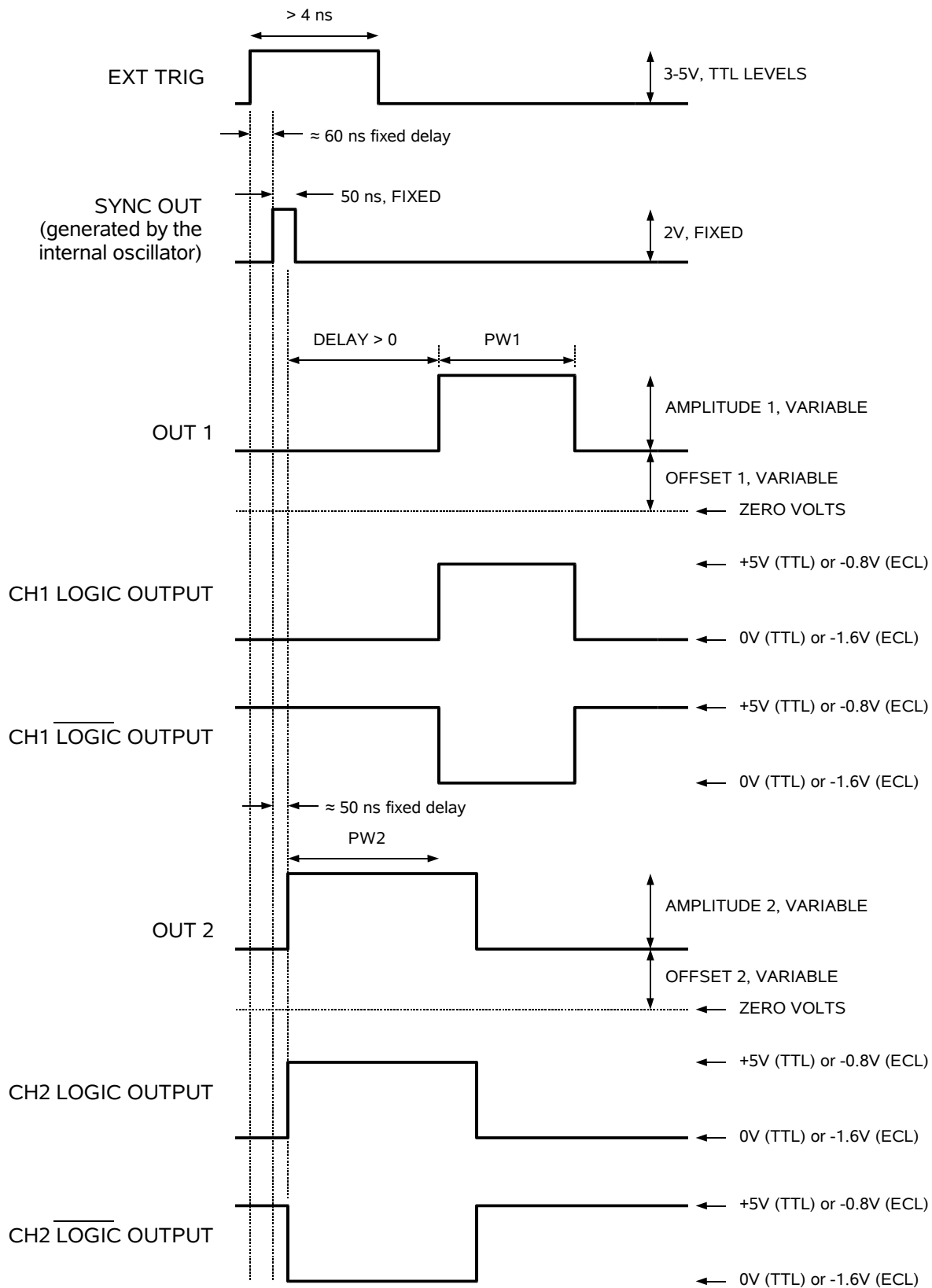

Figure B

TRIGGER MODES

This instrument has four basic trigger modes:

- Internal Trigger: the instrument controls the trigger frequency, and generates the clock internally.
- External Trigger: the instrument is triggered by an external TTL-level clock on the back-panel TRIG connector.
- Manual Trigger: the instrument is triggered by the front-panel “SINGLE PULSE” pushbutton.
- Hold Trigger: the instrument is set to not trigger at all.

These modes can be selected using the front panel trigger menu, or by using the appropriate programming commands. (See the “Programming Manual for -B Instruments” for more details.)

GATING

Triggering can be suppressed by a TTL-level signal on the rear-panel GATE connector. The instrument can be set to stop triggering when this input high or low, using the front-panel gate menu or the appropriate programming commands. This input will act synchronously, i.e., the output will complete the full pulse width if the output is high, and then stop triggering. No pulses are truncated in this mode.

SPECIAL CHANNEL 1 MODES: DC Output

Channel 1 has several features that are not available on Channel 2, including a DC mode. In this mode, the CH1 output is a steady DC level, rather than a pulsed output.

SPECIAL CHANNEL 1 MODES: Double Pulse

Channel 1 has several features that are not available on Channel 2, including a double Pulse Mode. In this mode, Channel 1 generates two pulses for every trigger. The first pulse occurs immediately after triggering, and the second pulse is delayed by programmed delay.

SPECIAL CHANNEL 1 MODES: $PW_{IN}=PW_{OUT}$ Mode

Channel 1 has several features that are not available on Channel 2, including a $PW_{IN}=PW_{OUT}$ Mode. In this mode, the Channel 1 output pulse width equals the pulse

width of the trigger signal on the “TRIG” connector. The delay circuit is bypassed to achieve this. (The Channel 2 pulse width is still programmed from the front panel, or via computer.)

OUTPUT TERMINATION

All of the outputs of the AV-1021D-B will drive 50Ω loads (i.e. OUT 1, OUT 2, the four logic outputs, and the SYNC output). They will also drive high-impedance loads (i.e. $R_L > 50\Omega$). However, the best waveforms will be obtained if 50Ω loads are used in conjunction with 50Ω coaxial cabling. Any other combination will unavoidably result in undesirable waveform ringing, due to mismatched-transmission-line effects.

As noted elsewhere, the output impedance of each of the two main outputs can be set at either 2Ω or 50Ω . When driving long lengths of cable, it is desirable to use the 50Ω mode, since this will provide an ideal transmission-line termination at the source (i.e., back-matching), so that ringing will be reduced even if the load is not 50Ω . The disadvantage is that the maximum output will be limited to $\pm 5V$ when driving 50Ω loads, due to the resistor-divider effect. If the full $\pm 10V$ is required when driving 50Ω loads, the 2Ω mode must be used. Whenever driving high impedance loads ($R_L \gg 50\Omega$) the 50Ω output impedance mode should be used, in order to minimise waveform distortion. Nearly the full $\pm 10V$ can be obtained since the resistor-divider effect is minimal for $R_L \gg 50\Omega$.

OPERATIONAL CHECK

This section describes a sequence to confirm the basic operation of the instrument. It should be performed after receiving the instrument. It is a useful learning exercise as well.

Before proceeding with this procedure, finish reading this instruction manual thoroughly. Then read the “Local Control” section of the “Programming Manual for -B Instruments” thoroughly. The “Local Control” section describes the front panel controls used in this operational check - in particular, the MOVE, CHANGE, and ADJUST controls.

1. Connect a cable from the SYNC OUT connector to the TRIG input of an oscilloscope. Connect a 2W (or higher), low-inductance (not wirewound) 50 Ω load to the OUT 1 connector and place the scope probe across this load. Do the same with a second load and probe to the OUT 2 connector. Set the oscilloscope to trigger externally with the vertical setting at 5 Volts/div and the horizontal setting at 100 ns/div.
2. Turn on the AV-1021D-B. The main menu will appear on the LCD.
3. To set the AV-1021D-B to trigger from the internal clock at a PRF of 1 MHz:
 - a) The arrow pointer should be pointing at the frequency menu item. If it is not, press the MOVE button until it is.
 - b) Press the CHANGE button. The frequency submenu will appear. Rotate the ADJUST knob until the frequency is set at 1 MHz.
 - c) The arrow pointer should be pointing at the “Internal” choice. If it is not, press MOVE until it is.
 - d) Press CHANGE to return to the main menu.
4. To set the delay to 100 ns:
 - a) Press the MOVE button until the arrow pointer is pointing at the delay menu item.
 - b) Press the CHANGE button. The delay submenu will appear. Rotate the ADJUST knob until the delay is set at 100 ns.
 - c) The arrow pointer should be pointing at the “Normal” choice. If it is not, press MOVE until it is.

- d) Press CHANGE to return to the main menu.
5. To set the Channel 1 pulse width to 150 ns:
 - a) Press the MOVE button until the arrow pointer is pointing at the "PW1" menu item.
 - b) Press the CHANGE button. The pulse width submenu will appear. Rotate the ADJUST knob until the pulse width is set at 150 ns.
 - c) The arrow pointer should be pointing at the "Normal" choice. If it is not, press MOVE until it is.
 - d) Press CHANGE to return to the main menu.
 6. To set the Channel 2 pulse width to 250 ns:
 - a) Press the MOVE button until the arrow pointer is pointing at the "PW2" menu item.
 - b) Press the CHANGE button. The pulse width submenu will appear. Rotate the ADJUST knob until the pulse width is set at 250 ns.
 - c) The arrow pointer should be pointing at the "Normal" choice. If it is not, press MOVE until it is.
 - d) Press CHANGE to return to the main menu.
 7. The main menu display should show that the output impedance (Z_{OUT}) is set at 2Ω for both channels. If it is different, change the settings.
 8. At this point, nothing should appear on the oscilloscope.
 9. To enable the output:
 - a) Press the MOVE button until the arrow pointer is pointing at the output menu item.
 - b) Press the CHANGE button. The output submenu will appear.
 - c) Press MOVE until the arrow pointer is pointing at the "ON" choice.
 - d) Press CHANGE to return to the main menu.
 10. To change the Channel 1 output amplitude:

- a) Press the MOVE button until the arrow pointer is pointing at the "AMP1" menu item.
 - b) Press the CHANGE button. The amplitude submenu will appear. Rotate the ADJUST knob until the amplitude is set at +10V.
 - c) Observe the oscilloscope. You should see 150 ns wide, 10V pulses.
 - d) Rotate the ADJUST knob. The amplitude as seen on the oscilloscope should vary. Return it to +10V.
 - e) Press CHANGE to return to the main menu.
11. To change the Channel 2 output amplitude:
- a) Press the MOVE button until the arrow pointer is pointing at the "AMP2" menu item.
 - b) Press the CHANGE button. The amplitude submenu will appear. Rotate the ADJUST knob until the amplitude is set at +5V.
 - c) Observe the oscilloscope. You should see 250 ns wide, 5V pulses.
 - d) Rotate the ADJUST knob. The amplitude as seen on the oscilloscope should vary.
 - e) Press CHANGE to return to the main menu.
12. Try varying the pulse width, by repeating step (6). As you rotate the ADJUST knob, the pulse width on the oscilloscope will change. It should agree with the displayed value.
13. Go to the "ZOUT1" output impedance menu, and set the output impedance (Z_{OUT}) to 50 Ω . If a 50 Ω load is attached to the output (see step 1) the Channel 1 amplitude should fall by a factor of 2, to 5V.
14. Set the output impedance (Z_{OUT}) back to 2 Ω and return to the main menu.
15. To change the output amplitude polarity:
- a) Press the MOVE button until the arrow pointer is pointing at the "AMPL1" menu item.
 - b) Press the CHANGE button. The amplitude submenu will appear.
 - c) Press the "+/-" button. The amplitude as seen on the oscilloscope should become negative.

- d) Press CHANGE to return to the main menu.
16. To add a DC offset:
- a) Press the MOVE button until the arrow pointer is pointing at the "OS1" menu item.
 - b) Press the CHANGE button. The offset submenu will appear. Rotate the ADJUST knob until the offset is set at 5V.
 - c) Observe the oscilloscope. You should see 150 ns wide pulses, swinging between +5V and -5V.
 - d) Press CHANGE to return to the main menu.
17. To set the logic outputs to TTL operation:
- a) Press the MOVE button until the arrow pointer is pointing at the "LOGIC1" menu item.
 - b) The arrow pointer should be pointing at the "TTL level" choice. If it is not, press MOVE until it is.
 - c) Press CHANGE to return to the main menu.
18. Move the 50 Ω load from the OUT 1 connector to the CH 1 LOGIC connector. Observe the waveform. You should see 150 ns wide pulses, swinging between 0 and +5V (approximately).
19. To set the logic outputs to ECL operation:
- a) Press the MOVE button until the arrow pointer is pointing at the "LOGIC1" menu item.
 - b) Press MOVE until the arrow pointer is pointing at the "ECL level" choice.
 - c) Press CHANGE to return to the main menu.
20. Observe the waveform. You should see 150 ns wide pulses, swinging between -1.6V and -0.8V (approximately).

This completes the operational check.

MECHANICAL INFORMATION

TOP COVER REMOVAL

If necessary, the interior of the instrument may be accessed by removing the four Phillips screws on the top panel. With the four screws removed, the top cover may be slid back (and off).

Always disconnect the power cord before opening the instrument.

There are no user-adjustable internal circuits. For repairs other than fuse replacement, please contact Avtech (info@avtechpulse.com) to arrange for the instrument to be returned to the factory for repair.

 Caution: High voltages are present inside the instrument during normal operation. Do not operate the instrument with the cover removed.

RACK MOUNTING

A rack mounting kit is available. The -R5 rack mount kit may be installed after first removing the one Phillips screw on the side panel adjacent to the front handle.

ELECTROMAGNETIC INTERFERENCE

To prevent electromagnetic interference with other equipment, all used outputs should be connected to shielded 50Ω loads using shielded 50Ω coaxial cables. Unused outputs should be terminated with shielded 50Ω coaxial terminators or with shielded coaxial dust caps, to prevent unintentional electromagnetic radiation. All cords and cables should be less than 3m in length.

MAINTENANCE

REGULAR MAINTENANCE

This instrument does not require any regular maintenance.

On occasion, one or more of the four rear-panel fuses may require replacement. All fuses can be accessed from the rear panel. See the “FUSES” section for details.

CLEANING

If desired, the interior of the instrument may be cleaned using compressed air to dislodge any accumulated dust. (See the “TOP COVER REMOVAL” section for instructions on accessing the interior.) No other cleaning is recommended.

PROGRAMMING YOUR PULSE GENERATOR

KEY PROGRAMMING COMMANDS

The “Programming Manual for -B Instruments” describes in detail how to connect the pulse generator to your computer, and the programming commands themselves. A large number of commands are available; however, normally you will only need a few of these. Here is a basic sample sequence of commands that might be sent to the instrument after power-up:

```
*rst                (resets the instrument)
trigger:source internal (selects internal triggering)
frequency 1000 Hz   (sets the frequency to 1000 Hz)
pulse:width1 10 us (sets the channel 1 pulse width to 10 us)
pulse:width2 20 us (sets the channel 2 pulse width to 20 us)
pulse:delay 1 us   (sets the inter-channel delay to 1 us)
output:impedance1 2 (sets the channel 1 output impedance to 2Ω. The only other
                    allowed setting is output:impedance1 50.)
output:impedance2 50 (sets the channel 2 output impedance to 50Ω.)
output:type1 TTL    (sets the channel 1 logic outputs to TTL mode)
output:type2 ECL    (sets the channel 2 logic outputs to ECL mode)
volt:ampl1 5        (sets the channel 1 amplitude to 5 V)
volt:ampl2 -5       (sets the channel 2 amplitude to -5 V)
volt:low1 0         (sets the DC offset to 0 V)
volt:low2 +2        (sets the DC offset to +2 V)
output on           (turns on the output)
```

For triggering a single event, this sequence would be more appropriate:

```
*rst                (resets the instrument)
trigger:source hold (turns off all triggering)
pulse:width1 10 us (sets the channel 1 pulse width to 10 us)
pulse:width2 20 us (sets the channel 2 pulse width to 20 us)
pulse:delay 1 us   (sets the inter-channel delay to 1 us)
output:impedance1 2 (sets the channel 1 output impedance to 2Ω. The only other
                    allowed setting is output:impedance1 50.)
output:impedance2 50 (sets the channel 2 output impedance to 50Ω.)
output:type1 TTL    (sets the channel 1 logic outputs to TTL mode)
output:type2 ECL    (sets the channel 2 logic outputs to ECL mode)
output on           (turns on the output)
volt:ampl1 5        (sets the channel 1 amplitude to 5 V)
volt:ampl2 -5       (sets the channel 2 amplitude to -5 V)
volt:low1 0         (sets the DC offset to 0 V)
volt:low2 +2        (sets the DC offset to +2 V)
trigger:source immediate (generates a single non-repetitive trigger event)
trigger:source hold (turns off all triggering)
```

output off (turns off the output)

To set the instrument to trigger from an external TTL signal applied to the rear-panel TRlg connector, use:

```
*rst (resets the instrument)
trigger:source external (selects internal triggering)
pulse:width1 10 us (sets the channel 1 pulse width to 10 us)
pulse:width2 20 us (sets the channel 2 pulse width to 20 us)
pulse:delay 1 us (sets the inter-channel delay to 1 us)
output:impedance1 2 (sets the channel 1 output impedance to 2Ω. The only other
allowed setting is output:impedance1 50.)
output:impedance2 50 (sets the channel 2 output impedance to 50Ω.)
output:type1 TTL (sets the channel 1 logic outputs to TTL mode)
output:type2 ECL (sets the channel 2 logic outputs to ECL mode)
output:type TTL (sets the logic outputs to TTL mode)
volt:ampl1 5 (sets the channel 1 amplitude to 5 V)
volt:ampl2 -5 (sets the channel 2 amplitude to -5 V)
volt:low1 0 (sets the DC offset to 0 V)
volt:low2 +2 (sets the DC offset to +2 V)
output on (turns on the output)
```

These commands will satisfy 90% of your programming needs.

ALL PROGRAMMING COMMANDS

For more advanced programmers, a complete list of the available commands is given below. These commands are described in detail in the “Programming Manual for -B Instruments”. (Note: this manual also includes some commands that are not implemented in this instrument. They can be ignored.)

<u>Keyword</u>	<u>Parameter</u>	<u>Notes</u>
LOCAL		
OUTPut:		
:[STATe]	<boolean value>	
:IMPedance	<numeric value>	
:PROTection		
:TRIPped?		[query only]
:TYPE	TTL ECL	
REMOTE		
[SOURce]:		
:FREQUency		
[:CW FIXed]	<numeric value>	
[SOURce]:		
:PULSe		
:PERiod	<numeric value>	
:WIDTh	<numeric value> EXT [EXT for CH1 only]	

:DCYCLE	<numeric value>	
:HOLD	WIDTH DCYCLE	
:DELAY	<numeric value>	
:DOUBLE		[CH1 only]
[:STATE]	<boolean value>	[CH1 only]
:DELAY	<numeric value>	[CH1 only]
:GATE		
:LEVEL	High Low	
[SOURCE]:		
:VOLTage		
[:LEVEL]		
[:IMMEDIATE]		
[:AMPLITUDE]	<numeric value>	
:LOW	<numeric value>	
:PROTECTION		
:TRIPPED?		[query only]
STATUS:		
:OPERATION		
:[EVENT]?		[query only, always returns "0"]
:CONDITION?		[query only, always returns "0"]
:ENABLE	<numeric value>	[implemented but not useful]
:QUESTIONABLE		
:[EVENT]?		[query only, always returns "0"]
:CONDITION?		[query only, always returns "0"]
:ENABLE	<numeric value>	[implemented but not useful]
SYSTEM:		
:COMMUNICATE		
:GPIB		
:ADDRESS	<numeric value>	
:SERIAL		
:CONTROL		
:RTS	ON IBFull RFR	
:[RECEIVE]		
:BAUD	1200 2400 4800 9600	
:BITS	7 8	
:ECHO	<boolean value>	
:PARITY		
:[TYPE]	EVEN ODD NONE	
:SBITS	1 2	
:ERROR		
:[NEXT]?		[query only]
:COUNT?		[query only]
:VERSION?		[query only]
TRIGGER:		
:SOURCE	INTERNAL EXTERNAL MANUAL HOLD IMMEDIATE	
*CLS		[no query form]
*ESE	<numeric value>	
*ESR?		[query only]
*IDN?		[query only]
*OPC		
*SAV	0 1 2 3	[no query form]
*RCL	0 1 2 3	[no query form]
*RST		[no query form]
*SRE	<numeric value>	
*STB?		[query only]
*TST?		[query only]
*WAI		[no query form]

WIRING DIAGRAMS

WIRING OF AC POWER

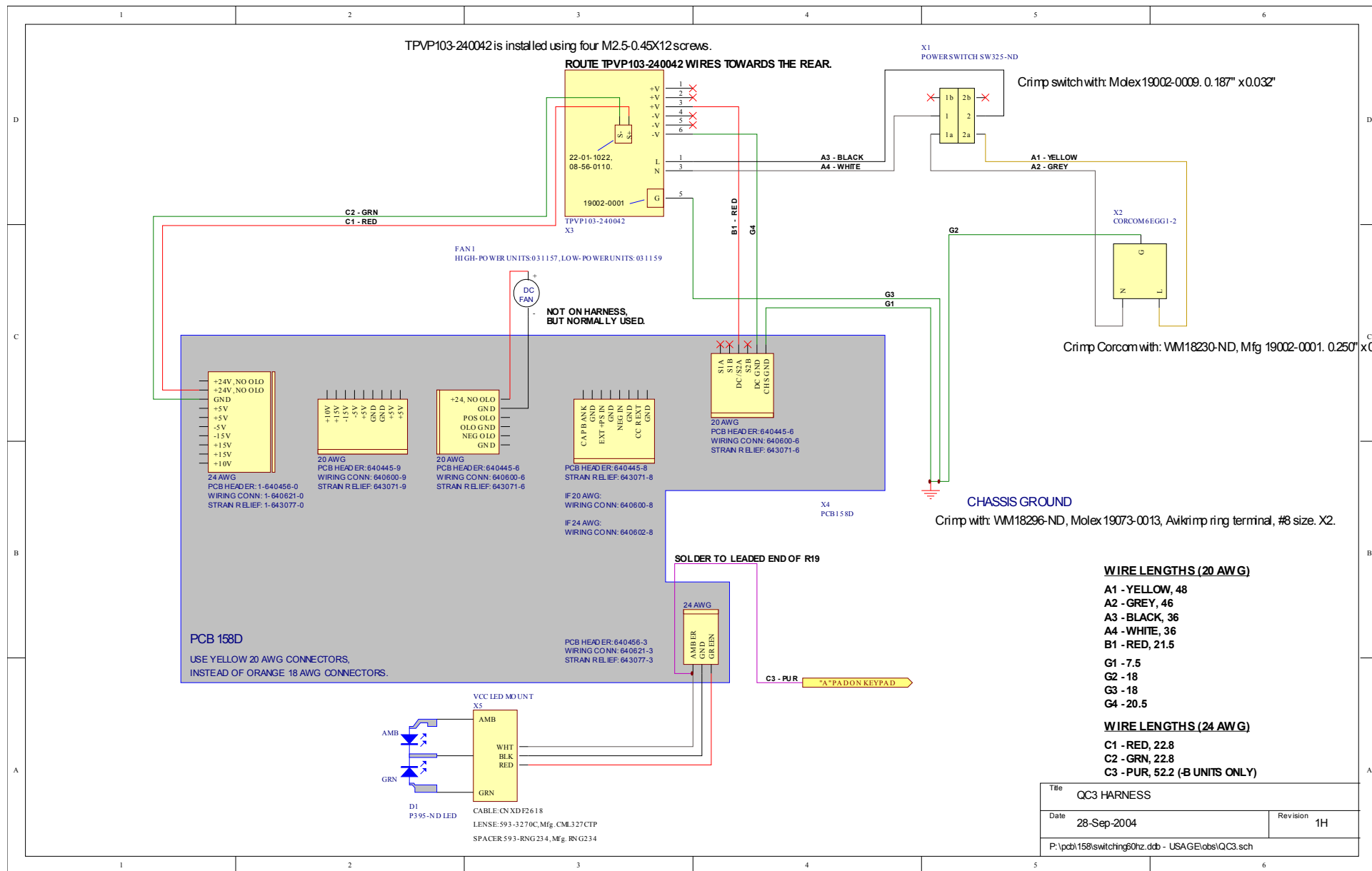

PCB 158D - LOW VOLTAGE POWER SUPPLY, 1/3

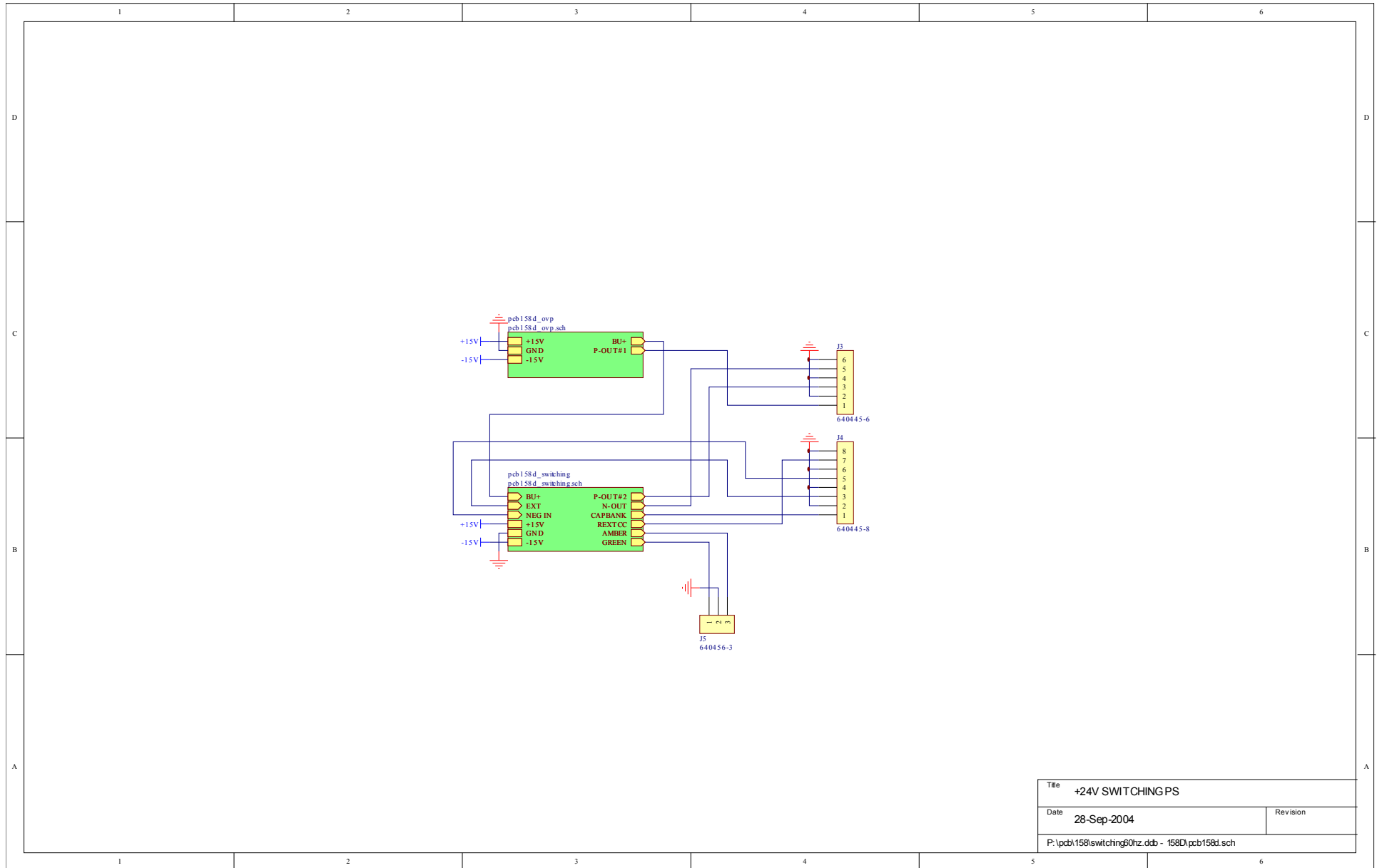

Title	+24V SWITCHING PS	
Date	28-Sep-2004	Revision
P:\pcb\158\switching60hz.ddb - 158D.pcb158d.sch		

PCB 158D - LOW VOLTAGE POWER SUPPLY, 2/3

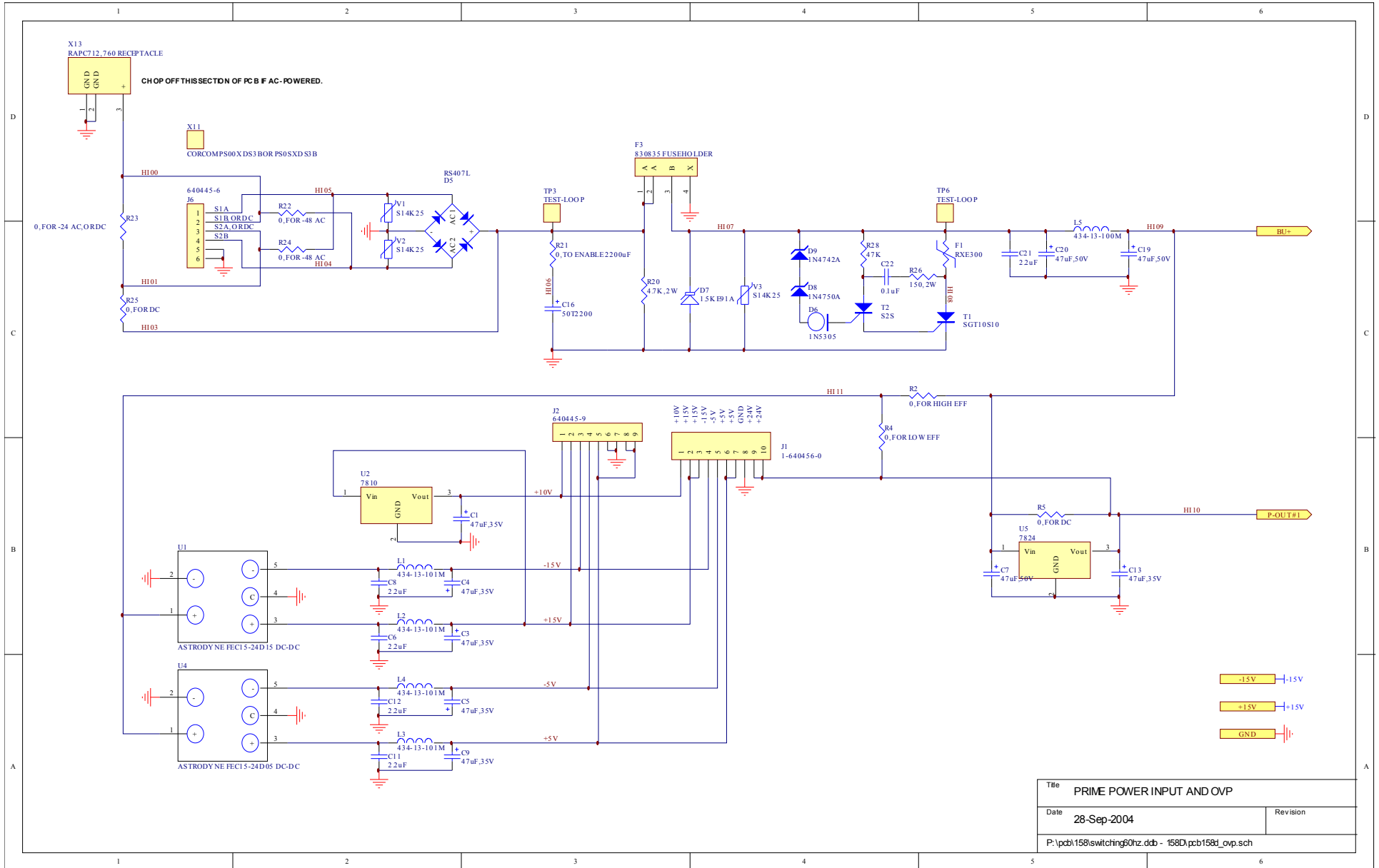

PCB 158D - LOW VOLTAGE POWER SUPPLY, 3/3

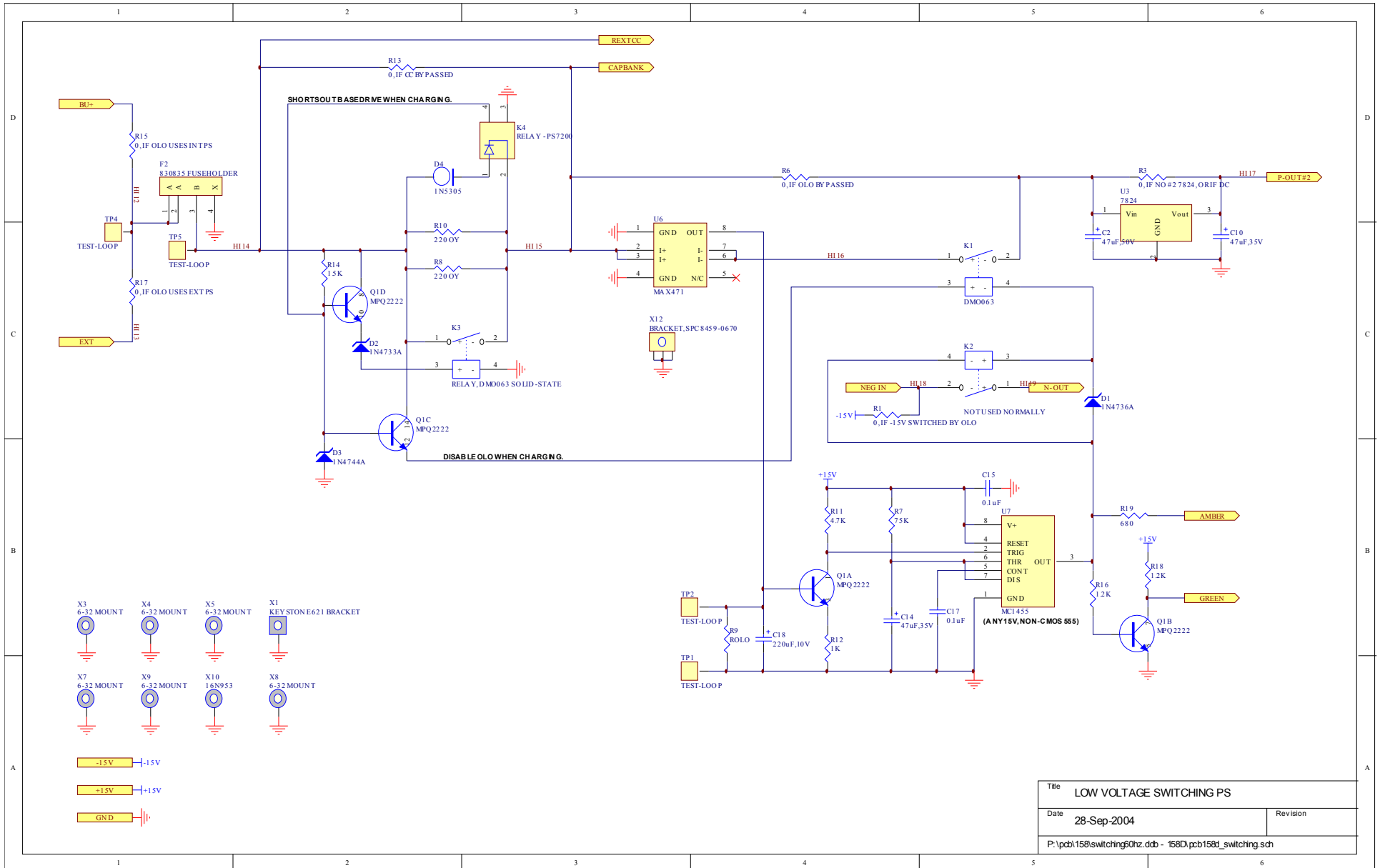

Title		LOW VOLTAGE SWITCHING PS
Date	28-Sep-2004	Revision
P:\pcb\158\switching60hz.ddb - 158D.pcb158d_switching.sch		

MAIN SIGNAL WIRING

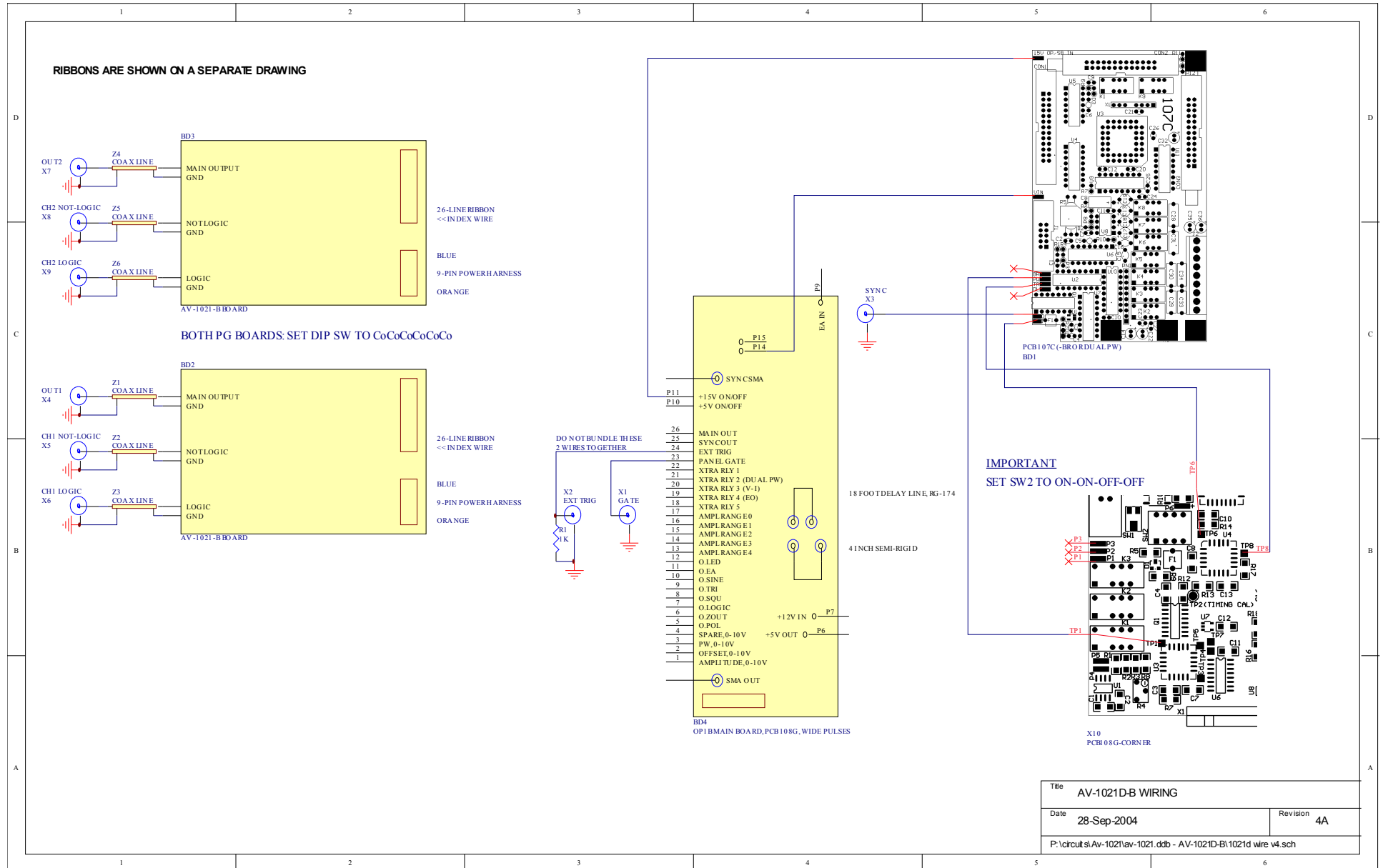

Title AV-1021-D-B WIRING	
Date 28-Sep-2004	Revision 4A
P:\circuits\Av-1021\av-1021.ddb - AV-1021-D-B\1021d wire v4.sch	

PCB 100 - OUTPUT SCHEMATIC, 1/4

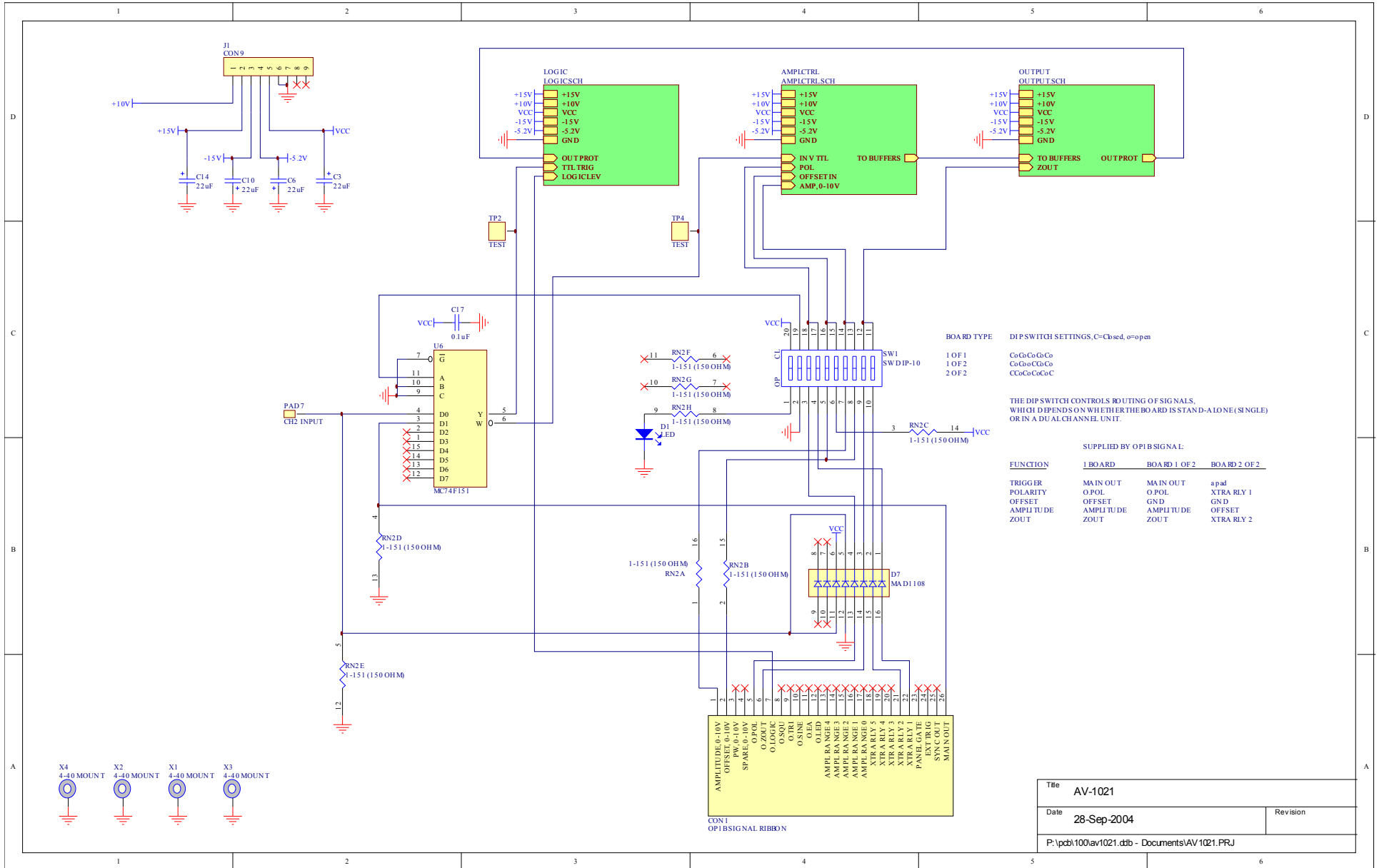

PCB 100 - OUTPUT SCHEMATIC, 2/4

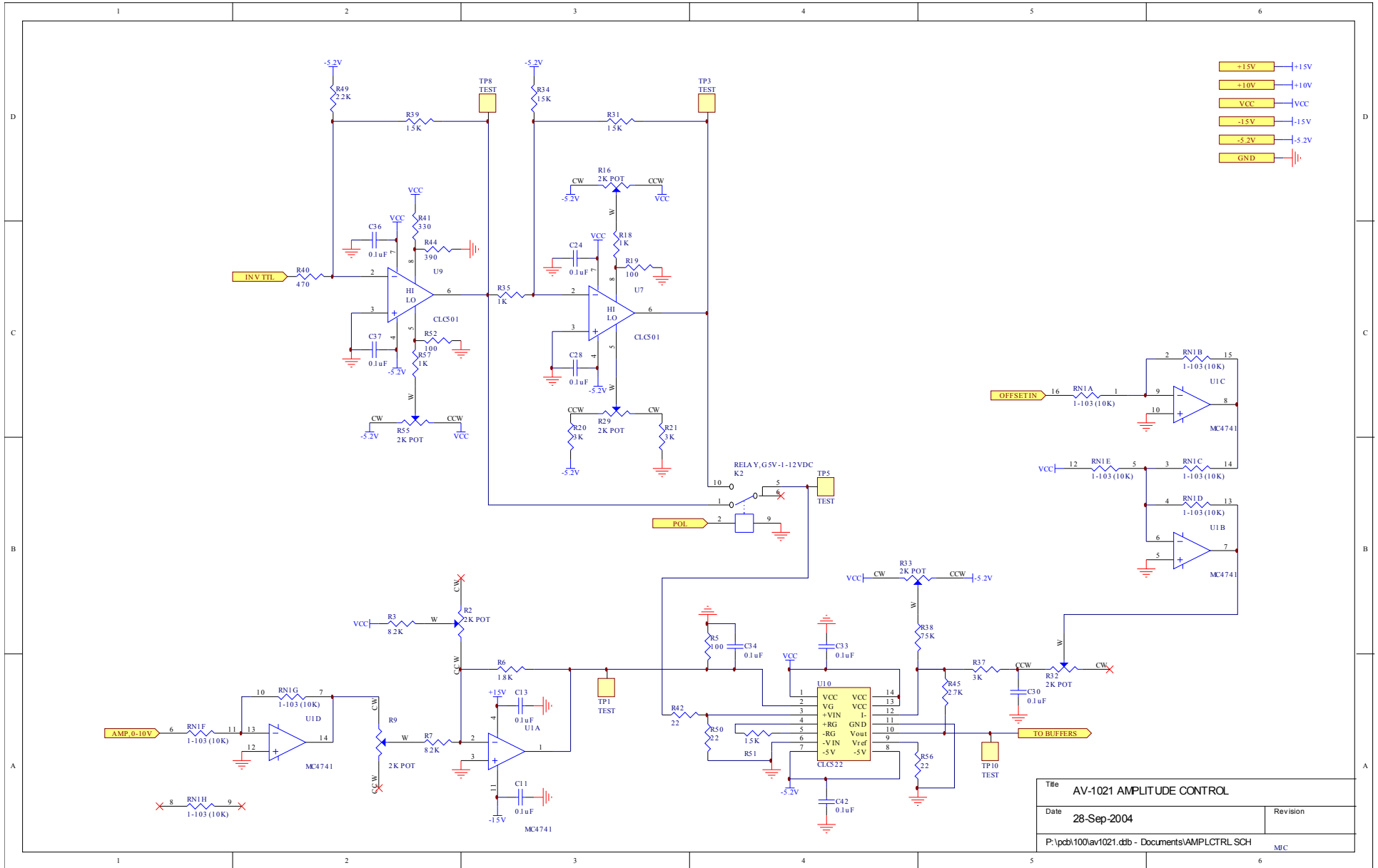

PCB 100 - OUTPUT SCHEMATIC, 3/4

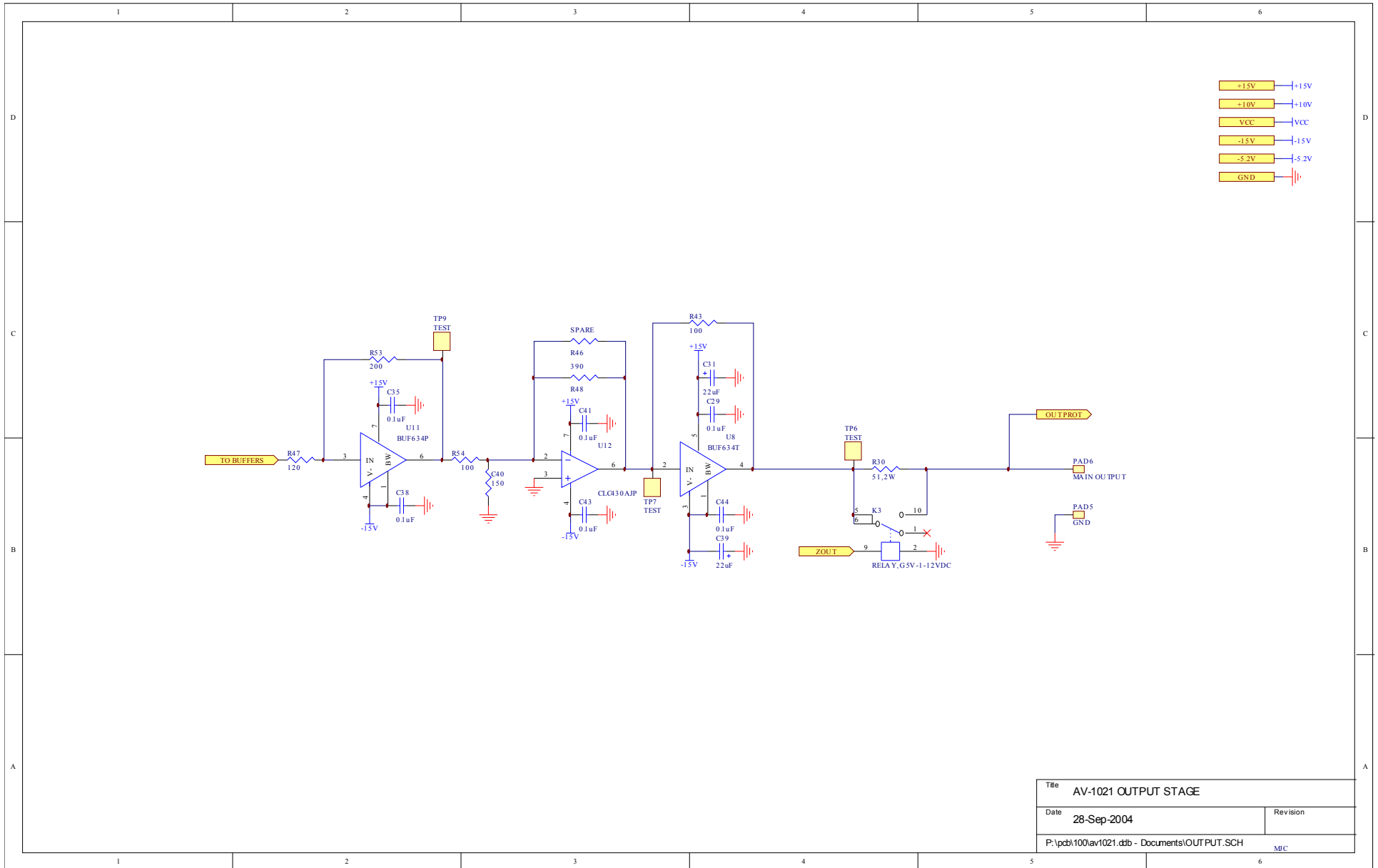

PCB 100 - OUTPUT SCHEMATIC, 4/4

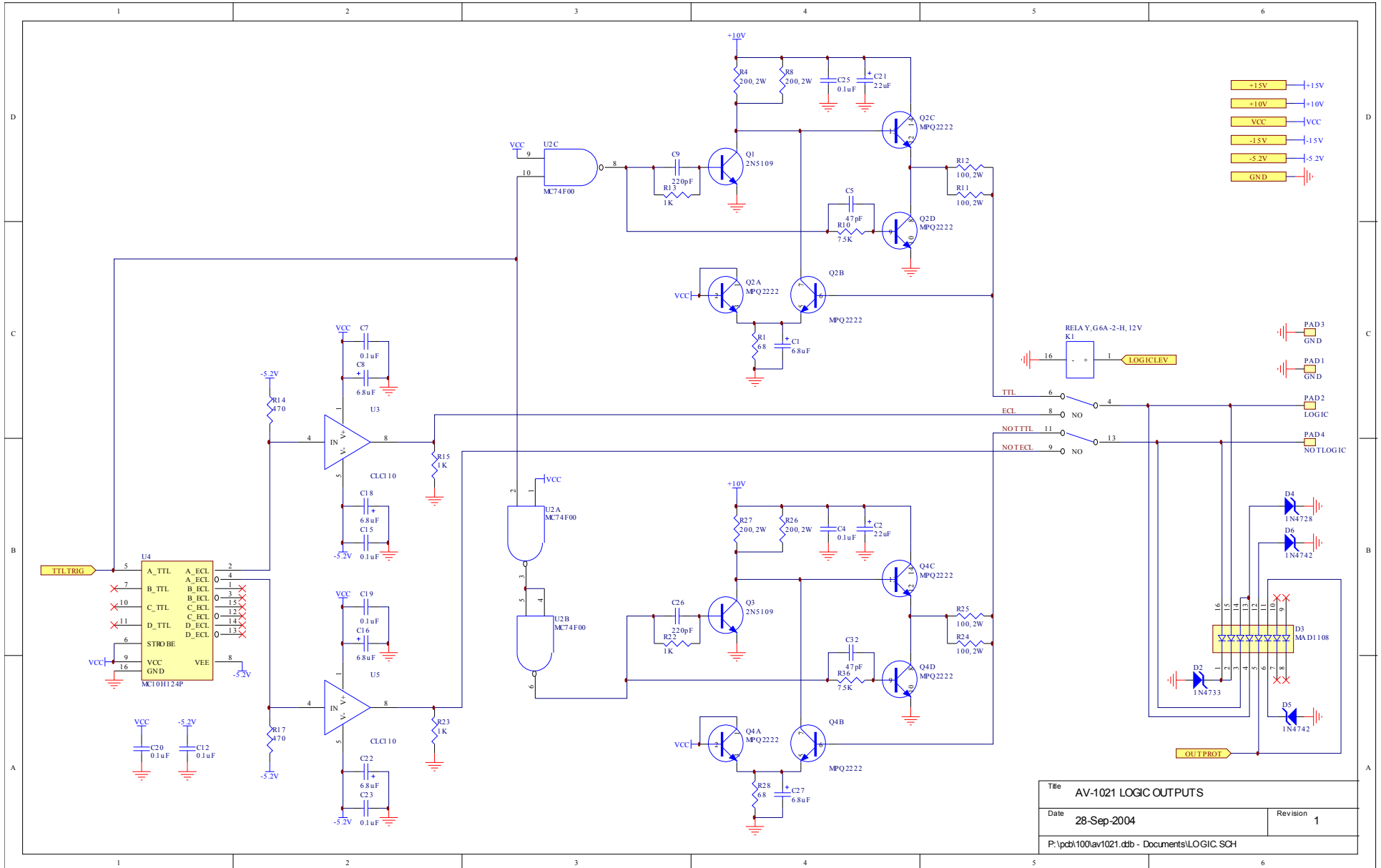

PERFORMANCE CHECK SHEET